

Chapter 2

Homogenous transformation matrices

2.1 Translational transformation

In the introductory chapter we have seen that robots have either translational or rotational joints. We therefore need a unified mathematical description of translational and rotational displacements. The translational displacement \mathbf{d} , given by the vector

$$\mathbf{d} = a\mathbf{i} + b\mathbf{j} + c\mathbf{k}, \quad (2.1)$$

can be described also by the following homogenous transformation matrix \mathbf{H}

$$\mathbf{H} = \text{Trans}(a, b, c) = \begin{bmatrix} 1 & 0 & 0 & a \\ 0 & 1 & 0 & b \\ 0 & 0 & 1 & c \\ 0 & 0 & 0 & 1 \end{bmatrix}. \quad (2.2)$$

When using homogenous transformation matrices an arbitrary vector has the following 4×1 form

$$\mathbf{q} = \begin{bmatrix} x \\ y \\ z \\ 1 \end{bmatrix} = [x \ y \ z \ 1]^T. \quad (2.3)$$

A translational displacement of vector \mathbf{q} for a distance \mathbf{d} is obtained by multiplying the vector \mathbf{q} with the matrix \mathbf{H}

$$\mathbf{v} = \begin{bmatrix} 1 & 0 & 0 & a \\ 0 & 1 & 0 & b \\ 0 & 0 & 1 & c \\ 0 & 0 & 0 & 1 \end{bmatrix} \begin{bmatrix} x \\ y \\ z \\ 1 \end{bmatrix} = \begin{bmatrix} x+a \\ y+b \\ z+c \\ 1 \end{bmatrix}. \quad (2.4)$$

The translation, which is presented by multiplication with a homogenous matrix, is equivalent to the sum of vectors \mathbf{q} and \mathbf{d}

$$\mathbf{v} = \mathbf{q} + \mathbf{d} = (x\mathbf{i} + y\mathbf{j} + z\mathbf{k}) + (a\mathbf{i} + b\mathbf{j} + c\mathbf{k}) = (x+a)\mathbf{i} + (y+b)\mathbf{j} + (z+c)\mathbf{k}. \quad (2.5)$$

In a simple example, the vector $2\mathbf{i} + 3\mathbf{j} + 2\mathbf{k}$ is translationally displaced for the distance $4\mathbf{i} - 3\mathbf{j} + 7\mathbf{k}$

$$\mathbf{v} = \begin{bmatrix} 1 & 0 & 0 & 4 \\ 0 & 1 & 0 & -3 \\ 0 & 0 & 1 & 7 \\ 0 & 0 & 0 & 1 \end{bmatrix} \begin{bmatrix} 2 \\ 3 \\ 2 \\ 1 \end{bmatrix} = \begin{bmatrix} 6 \\ 0 \\ 9 \\ 1 \end{bmatrix}.$$

The same result is obtained by adding the two vectors.

2.2 Rotational transformation

Rotational displacements will be described in a right-handed rectangular coordinate frame, where the rotations around the three axes, as shown in Figure 2.1, are considered as positive. Positive rotations around the selected axis are counter-clockwise when looking from the positive end of the axis towards the origin of the frame O . The positive rotation can be described also by the so called right hand rule, where the thumb is directed along the axis towards its positive end, while the fingers show the positive direction of the rotational displacement. The direction of running of athletes on a stadium is also an example of a positive rotation.

Let us first take a closer look at the rotation around the x axis. The coordinate frame x', y', z' shown in Figure 2.2 was obtained by rotating the reference frame x, y, z in the positive direction around the x axis for the angle α . The axes x and x' are collinear.

The rotational displacement is also described by a homogenous transformation matrix. The first three rows of the transformation matrix correspond to the x, y and z axes of the reference frame, while the first three columns refer to the x', y' and z'

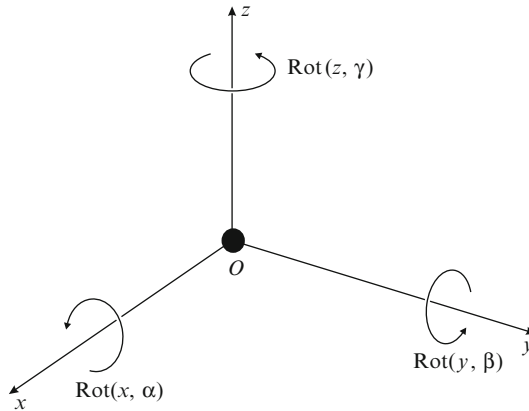

Fig. 2.1 Right-hand rectangular frame with positive rotations

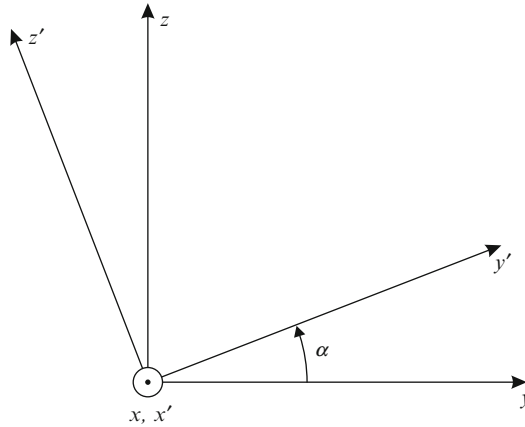

Fig. 2.2 Rotation around x axis

axes of the rotated frame. The upper left nine elements of the matrix \mathbf{H} represent the 3×3 rotation matrix. The elements of the rotation matrix are cosines of the angles between the axes given by the corresponding column and row

$$\begin{aligned}
 \text{Rot}(x, \alpha) &= \begin{bmatrix} x' & y' & z' & \\ \cos 0^\circ & \cos 90^\circ & \cos 90^\circ & 0 \\ \cos 90^\circ & \cos \alpha & \cos(90^\circ + \alpha) & 0 \\ \cos 90^\circ & \cos(90^\circ - \alpha) & \cos \alpha & 0 \\ 0 & 0 & 0 & 1 \end{bmatrix} \begin{matrix} x \\ y \\ z \end{matrix} \\
 &= \begin{bmatrix} 1 & 0 & 0 & 0 \\ 0 & \cos \alpha & -\sin \alpha & 0 \\ 0 & \sin \alpha & \cos \alpha & 0 \\ 0 & 0 & 0 & 1 \end{bmatrix}.
 \end{aligned} \tag{2.6}$$

The angle between the x' and the x axes is 0° , therefore we have $\cos 0^\circ$ in the intersection of the x' column and the x row. The angle between the x' and the y axes is 90° , we put $\cos 90^\circ$ in the corresponding intersection. The angle between the y' and the y axes is α , the corresponding matrix element is $\cos \alpha$.

To become more familiar with rotation matrices, we shall derive the matrix describing a rotation around the y axis by using Figure 2.3. Now the collinear axes are y and y'

$$y = y'. \tag{2.7}$$

By considering the similarity of triangles in Figure 2.3, it is not difficult to derive the following two equations

$$\begin{aligned}
 x &= x' \cos \beta + z' \sin \beta \\
 z &= -x' \sin \beta + z' \cos \beta.
 \end{aligned} \tag{2.8}$$

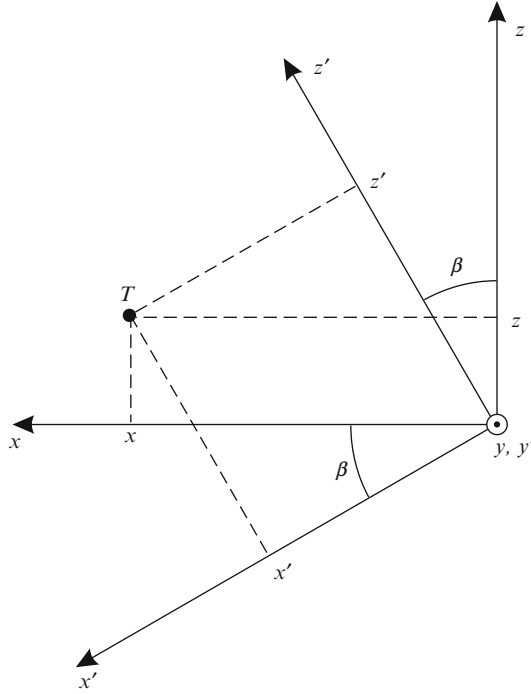

Fig. 2.3 Rotation around y axis

All three equations (2.7) and (2.8) can be rewritten in the matrix form

$$Rot(y, \beta) = \begin{bmatrix} x' & y' & z' \\ \cos \beta & 0 & \sin \beta & 0 \\ 0 & 1 & 0 & 0 \\ -\sin \beta & 0 & \cos \beta & 0 \\ 0 & 0 & 0 & 1 \end{bmatrix} \begin{bmatrix} x \\ y \\ z \end{bmatrix}. \quad (2.9)$$

The rotation around the z axis is described by the following homogenous transformation matrix

$$Rot(z, \gamma) = \begin{bmatrix} \cos \gamma & -\sin \gamma & 0 & 0 \\ \sin \gamma & \cos \gamma & 0 & 0 \\ 0 & 0 & 1 & 0 \\ 0 & 0 & 0 & 1 \end{bmatrix}. \quad (2.10)$$

In a simple numerical example we wish to determine the vector \mathbf{w} which is obtained by rotating the vector $\mathbf{u} = 7\mathbf{i} + 3\mathbf{j} + 0\mathbf{k}$ for 90° in the counter clockwise i.e. positive direction around the z axis. As $\cos 90^\circ = 0$ and $\sin 90^\circ = 1$, it is not difficult to determine the matrix describing $Rot(z, 90^\circ)$ and multiplying it by the vector \mathbf{u}

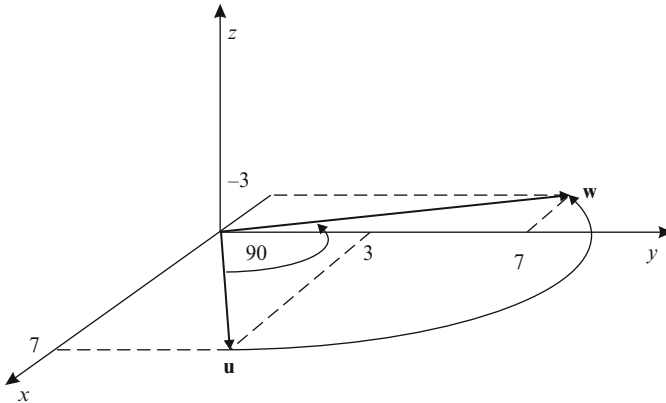

Fig. 2.4 Example of rotational transformation

$$\mathbf{w} = \begin{bmatrix} 0 & -1 & 0 & 0 \\ 1 & 0 & 0 & 0 \\ 0 & 0 & 1 & 0 \\ 0 & 0 & 0 & 1 \end{bmatrix} \begin{bmatrix} 7 \\ 3 \\ 0 \\ 1 \end{bmatrix} = \begin{bmatrix} -3 \\ 7 \\ 0 \\ 1 \end{bmatrix}.$$

The graphical presentation of rotating the vector \mathbf{u} around the z axis is shown in Figure 2.4.

2.3 Pose and displacement

In the previous section we have learned how a point is translated or rotated around the axes of the cartesian frame. In continuation we shall be interested in displacements of objects. We can always attach a coordinate frame to a rigid object under consideration. In this section we shall deal with the pose and the displacement of rectangular frames. We shall see that a homogenous transformation matrix describes either the pose of a frame with respect to a reference frame, or it represents the displacement of a frame into a new pose. In the first case the upper left 3×3 matrix represents the orientation of the object, while the right-hand 3×1 column describes its position (e.g. the position of its center of mass). The last row of the homogenous transformation matrix will be always represented by 0, 0, 0, 1. In the case of object displacement, the upper left matrix corresponds to rotation and the right-hand column corresponds to translation of the object. We shall examine both cases through simple examples. Let us first clear up the meaning of the homogenous transformation matrix describing the pose of an arbitrary frame with respect to the reference frame. Let us consider the following product of homogenous matrices which gives a new homogenous transformation matrix \mathbf{H}

$$\begin{aligned}
 \mathbf{H} &= \text{Trans}(4, -3, 7) \text{Rot}(y, 90^\circ) \text{Rot}(z, 90^\circ) \\
 &= \begin{bmatrix} 1 & 0 & 0 & 4 \\ 0 & 1 & 0 & -3 \\ 0 & 0 & 1 & 7 \\ 0 & 0 & 0 & 1 \end{bmatrix} \begin{bmatrix} 0 & 0 & 1 & 0 \\ 0 & 1 & 0 & 0 \\ -1 & 0 & 0 & 0 \\ 0 & 0 & 0 & 1 \end{bmatrix} \begin{bmatrix} 0 & -1 & 0 & 0 \\ 1 & 0 & 0 & 0 \\ 0 & 0 & 1 & 0 \\ 0 & 0 & 0 & 1 \end{bmatrix} \\
 &= \begin{bmatrix} 0 & 0 & 1 & 4 \\ 1 & 0 & 0 & -3 \\ 0 & 1 & 0 & 7 \\ 0 & 0 & 0 & 1 \end{bmatrix}.
 \end{aligned} \tag{2.11}$$

When defining the homogenous matrix representing rotation, we learned that the first three columns describe the rotation of the frame x' , y' , z' with respect to the reference frame x , y , z

$$\begin{array}{c} x' \quad y' \quad z' \\ \begin{bmatrix} [0] & [0] & [1] & 4 \\ 1 & 0 & 0 & -3 \\ [0] & [1] & [0] & 7 \\ 0 & 0 & 0 & 1 \end{bmatrix} \begin{array}{l} x \\ y \\ z \end{array} \end{array} \tag{2.12}$$

The fourth column represents the position of the origin of the frame x' , y' , z' with respect to the reference frame x , y , z . With this knowledge we can represent graphically the frame x' , y' , z' described by the homogenous transformation matrix (2.11), relative to the reference frame x , y , z (Figure 2.5). The x' axis points in the direction of y axis of the reference frame, the y' axis is in the direction of the z axis, and the z' axis is in the x direction.

To convince ourselves of the correctness of the frame drawn in Figure 2.6, we shall check the displacements included in equation (2.11). The reference frame is

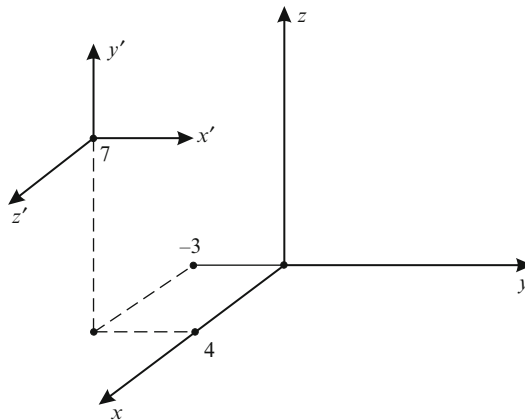

Fig. 2.5 The pose of an arbitrary frame $[x' y' z']$ with respect to the reference frame $[x y z]$

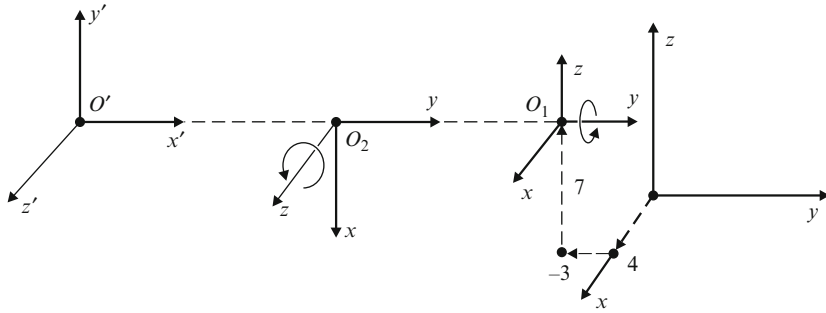

Fig. 2.6 Displacement of the reference frame into a new pose (from right to left). The origins O_1 , O_2 and O' are in the same point

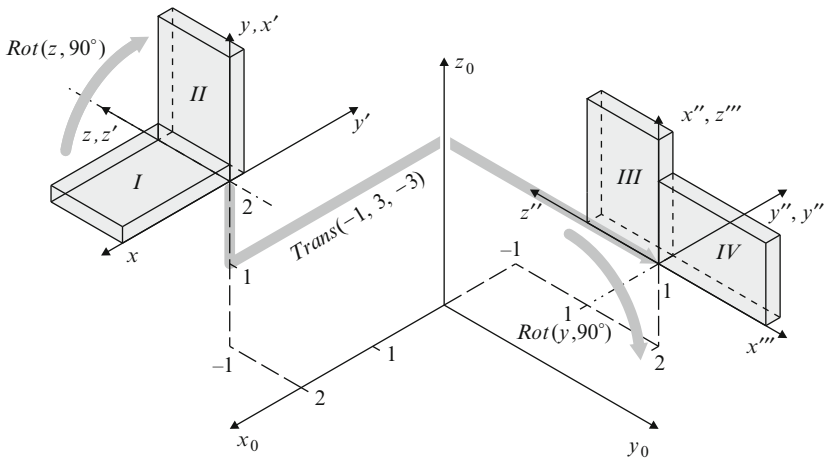

Fig. 2.7 Displacement of the object into a new pose

first translated into the point $[4, -3, 7]^T$, afterwards it is rotated for 90° around the new y axis and finally it is rotated for 90° around the newest z axis (Figure 2.6). The three displacements of the reference frame result in the same final pose as shown in Figure 2.5.

In continuation of this chapter we wish to elucidate the second meaning of the homogenous transformation matrix, i.e. a displacement of an object or coordinate frame into a new pose (Figure 2.7). First, we wish to rotate the coordinate frame x, y, z for 90° in the counter-clockwise direction around the z axis. This can be achieved by the following postmultiplication of the matrix \mathbf{H} describing the initial pose of the coordinate frame x, y, z

$$\mathbf{H}_1 = \mathbf{H} \cdot \text{Rot}(z, 90^\circ). \tag{2.13}$$

The displacement resulted in a new pose of the object and new frame x', y', z' shown in Figure 2.7. We shall displace this new frame for -1 along the x' axis, 3 units along y' axis and -3 along z' axis

$$\mathbf{H}_2 = \mathbf{H}_1 \cdot \text{Trans}(-1, 3, -3). \quad (2.14)$$

After translation a new pose of the object is obtained together with a new frame x'', y'', z'' . This frame will be finally rotated for 90° around the y'' axis in the positive direction

$$\mathbf{H}_3 = \mathbf{H}_2 \cdot \text{Rot}(y'', 90^\circ). \quad (2.15)$$

The equations (2.13), (2.14) and (2.15) can be successively inserted one into another

$$\mathbf{H}_3 = \mathbf{H} \cdot \text{Rot}(z, 90^\circ) \cdot \text{Trans}(-1, 3, -3) \cdot \text{Rot}(y'', 90^\circ) = \mathbf{H} \cdot \mathbf{D}. \quad (2.16)$$

In equation (2.16) the matrix \mathbf{H} represents the initial pose of the frame, \mathbf{H}_3 is the final pose, while \mathbf{D} represents the displacement

$$\begin{aligned} \mathbf{D} &= \text{Rot}(z, 90^\circ) \cdot \text{Trans}(-1, 3, -3) \cdot \text{Rot}(y'', 90^\circ) \\ &= \begin{bmatrix} 0 & -1 & 0 & 0 \\ 1 & 0 & 0 & 0 \\ 0 & 0 & 1 & 0 \\ 0 & 0 & 0 & 1 \end{bmatrix} \begin{bmatrix} 1 & 0 & 0 & -1 \\ 0 & 1 & 0 & 3 \\ 0 & 0 & 1 & -3 \\ 0 & 0 & 0 & 1 \end{bmatrix} \begin{bmatrix} 0 & 0 & 1 & 0 \\ 0 & 1 & 0 & 0 \\ -1 & 0 & 0 & 0 \\ 0 & 0 & 0 & 1 \end{bmatrix} \\ &= \begin{bmatrix} 0 & -1 & 0 & -3 \\ 0 & 0 & 1 & -1 \\ -1 & 0 & 0 & -3 \\ 0 & 0 & 0 & 1 \end{bmatrix}. \end{aligned} \quad (2.17)$$

Finally we shall perform the postmultiplication describing the new relative pose of the object

$$\begin{aligned} \mathbf{H}_3 = \mathbf{H} \cdot \mathbf{D} &= \begin{bmatrix} 1 & 0 & 0 & 2 \\ 0 & 0 & -1 & -1 \\ 0 & 1 & 0 & 2 \\ 0 & 0 & 0 & 1 \end{bmatrix} \begin{bmatrix} 0 & -1 & 0 & -3 \\ 0 & 0 & 1 & -1 \\ -1 & 0 & 0 & -3 \\ 0 & 0 & 0 & 1 \end{bmatrix} \\ &= \begin{matrix} x''' & y''' & z''' \\ \begin{bmatrix} 0 & -1 & 0 & -1 \\ 1 & 0 & 0 & 2 \\ 0 & 0 & 1 & 1 \\ 0 & 0 & 0 & 1 \end{bmatrix} \begin{matrix} x_0 \\ y_0 \\ z_0 \end{matrix} \end{matrix} \end{aligned} \quad (2.18)$$

As in the previous example we shall graphically verify the correctness of the matrix (2.18). The three displacements of the frame x, y, z : rotation for 90° in counter-clockwise direction around the z axis, translation for -1 along the x' axis,

3 units along y' axis and -3 along z' axis, and rotation for 90° around y'' axis in the positive direction are shown in Figure 2.7. The result is the final pose of the object x''' , y''' , z''' . The x''' axis points in the positive direction of the y_0 axis, y''' points in the negative direction of x_0 axis and z''' points in the positive direction of z_0 axis of the reference frame. The directions of the axes of the final frame correspond to the first three columns of the matrix \mathbf{H}_3 . There is also agreement between the position of the origin of the final frame in Figure 2.7 and the fourth column of the matrix \mathbf{H}_3 .

2.4 Geometrical robot model

Our final goal is the geometrical model of a robot manipulator. A geometrical robot model is given by the description of the pose of the last segment of the robot (end-effector) expressed in the reference (base) frame. The knowledge how to describe the pose of an object by the use of homogenous transformation matrices will be first applied to the process of assembly. For this purpose a mechanical assembly consisting of four blocks, such as presented in Figure 2.8, will be considered. A plate with dimensions $(5 \times 15 \times 1)$ is placed over a block $(5 \times 4 \times 10)$. Another plate $(8 \times 4 \times 1)$ is positioned perpendicularly to the first one, holding another small block $(1 \times 1 \times 5)$.

A frame is attached to each of the four blocks as shown in Figure 2.8. Our task will be to calculate the pose of the O_3 frame with respect to the reference frame O_0 . In the last chapter we learned that the pose of a displaced frame can be expressed

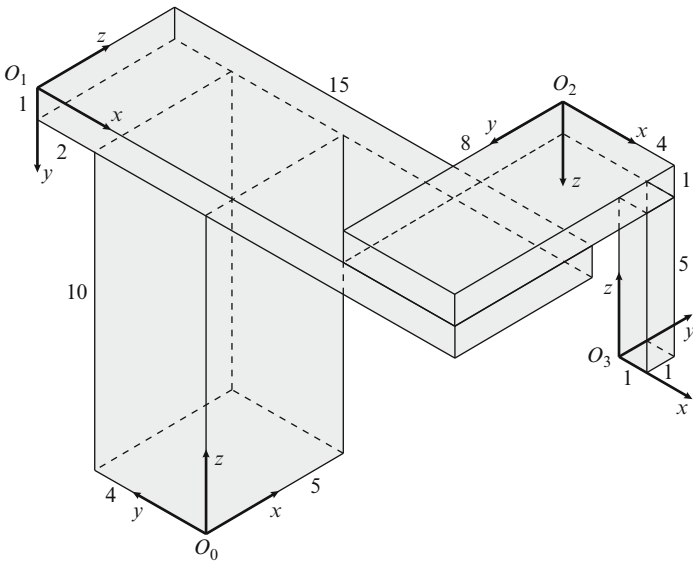

Fig. 2.8 Mechanical assembly

with respect to the reference frame by the use of the homogenous transformation matrix \mathbf{H} . The pose of the frame O_1 with respect to the frame O_0 will be denoted by ${}^0\mathbf{H}_1$. In the same way ${}^1\mathbf{H}_2$ represents the pose of O_2 frame with respect to O_1 and ${}^2\mathbf{H}_3$ the pose of O_3 with regard to O_2 frame. We learned also that the successive displacements are expressed by postmultiplications (successive multiplications from left to right) of homogenous transformation matrices. Also the assembly process can be described by postmultiplication of the corresponding matrices. The pose of the fourth block can be written with respect to the first one by the following matrix

$${}^0\mathbf{H}_3 = {}^0\mathbf{H}_1 {}^1\mathbf{H}_2 {}^2\mathbf{H}_3. \quad (2.19)$$

The blocks were positioned perpendicularly one to another. In this way it is not necessary to calculate the sines and cosines of the rotation angles. The matrices can be determined directly from Figure 2.8. The x axis of O_1 frame points in negative direction of the y axis in the O_0 frame. The y axis of O_1 frame points in negative direction of the z axis in the O_0 frame. The z axis of the O_1 frame has the same direction as x axis of the O_0 frame. The described geometrical properties of the assembly structure are written into the first three columns of the homogenous matrix. The position of the origin of the O_1 frame with respect to the O_0 frame is written into the fourth column

$${}^0\mathbf{H}_1 = \begin{array}{c} \overbrace{\begin{array}{ccc} x & y & z \end{array}}^{O_1} \\ \left[\begin{array}{cccc} 0 & 0 & 1 & 0 \\ -1 & 0 & 0 & 6 \\ 0 & -1 & 0 & 11 \\ 0 & 0 & 0 & 1 \end{array} \right] \begin{array}{l} x \\ y \\ z \end{array} \end{array} \Bigg\} O_0. \quad (2.20)$$

In the same way the other two matrices are determined

$${}^1\mathbf{H}_2 = \begin{bmatrix} 1 & 0 & 0 & 11 \\ 0 & 0 & 1 & -1 \\ 0 & -1 & 0 & 8 \\ 0 & 0 & 0 & 1 \end{bmatrix} \quad (2.21)$$

$${}^2\mathbf{H}_3 = \begin{bmatrix} 1 & 0 & 0 & 3 \\ 0 & -1 & 0 & 1 \\ 0 & 0 & -1 & 6 \\ 0 & 0 & 0 & 1 \end{bmatrix}. \quad (2.22)$$

The position and orientation of the fourth block with respect to the first one is given by the ${}^0\mathbf{H}_3$ matrix which is obtained by successive multiplication of the matrices (2.20), (2.21) and (2.22)

$${}^0\mathbf{H}_3 = \begin{bmatrix} 0 & 1 & 0 & 7 \\ -1 & 0 & 0 & -8 \\ 0 & 0 & 1 & 6 \\ 0 & 0 & 0 & 1 \end{bmatrix}. \quad (2.23)$$

The fourth column of the matrix ${}^0\mathbf{H}_3[7, -8, 6, 1]^T$ represents the position of the origin of the O_3 frame with respect to the reference frame O_0 . The correctness of the fourth column can be checked from Figure 2.8. The rotational part of the matrix ${}^0\mathbf{H}_3$ represents the orientation of the O_3 frame with respect to the reference frame O_0 .

Now let us imagine that the first horizontal plate rotates with respect to the first vertical block around axis 1 for angle ϑ_1 . The second plate also rotates around the vertical axis 2 for angle ϑ_2 . The last block is elongated for distance d_3 along the third axis. In this way we obtained a robot manipulator, which was named SCARA in the introductory chapter.

Our goal is to develop a geometrical model of the SCARA robot. Blocks and plates from Figure 2.9 will be replaced by symbols for rotational and translational joints that we know from the introduction (Figure 2.10).

The first vertical segment with the length l_1 starts from the basis, where the robot is attached to the ground, and is terminated by the first rotational joint. The second segment with length l_2 is horizontal and rotates around the first segment. The rotation in the first joint is denoted by the angle ϑ_1 . The third segment with the length l_3 is also horizontal and rotates around the vertical axis at the end of the second

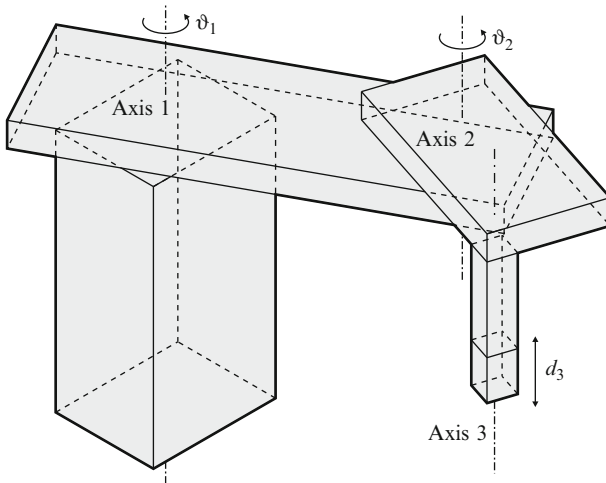

Fig. 2.9 Displacements of the mechanical assembly

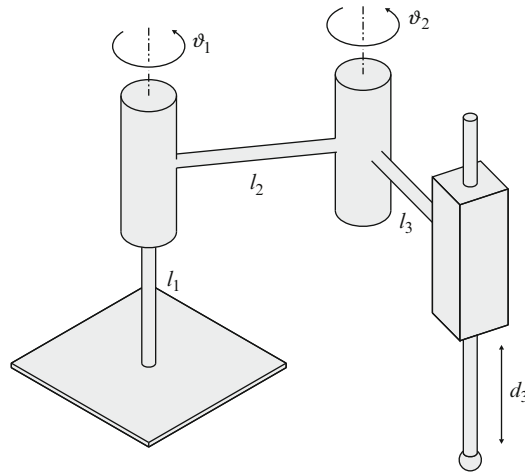

Fig. 2.10 SCARA robot manipulator in an arbitrary pose

segment. The angle is denoted as ϑ_2 . There is a translational joint at the end of the third segment. It enables the robot end-effector to approach the working plane where the robot task takes place. The translational joint is displaced from zero initial length to the length described by the variable d_3 .

The robot mechanism is first brought to the initial pose which is also called “home position”. In the initial pose two neighboring segments must be either parallel or perpendicular. The translational joints are in their initial position $d_i = 0$. The initial pose of the SCARA manipulator is shown in Figure 2.11.

First, the coordinate frames must be drawn into the SCARA robot presented in Figure 2.11. The first (reference) coordinate frame x_0, y_0, z_0 is placed onto the base of the robot. In the last chapter we shall learn that robot standards require the z_0 axis to point perpendicularly out from the base. In this case it is aligned with the first segment. The other two axes are selected in such a way that robot segments are parallel to one of the axes of the reference coordinate frame, when the robot is in its initial home position. In our case we align the y_0 axis with the segments l_2 and l_3 . The coordinate frame must be right handed. The rest of the frames are placed into the robot joints. The origins of the frames are drawn in the center of each joint. One of the frame axes must be aligned with the joint axis. The simplest way to calculate the geometrical model of a robot is to make all the frames in the robot joints parallel to the reference frame (Figure 2.11).

The geometrical model of a robot describes the pose of the frame attached to the end-effector with respect to the reference frame on the robot base. Similar to the case of the mechanical assembly, we shall obtain the geometrical model by successive multiplication (postmultiplication) of homogenous transformation matrices. The main difference between the mechanical assembly and the robot manipulator are the displacements of robot joints. For this purpose, each matrix ${}^{i-1}\mathbf{H}_i$ describing the pose of a segment will be followed by a matrix \mathbf{D}_i representing the displacement

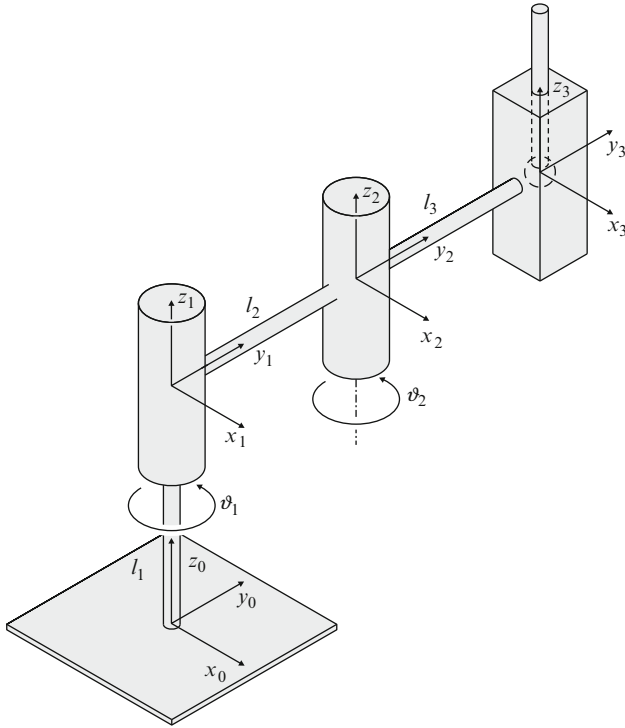

Fig. 2.11 The SCARA robot manipulator in the initial pose

of either the translational or the rotational joint. Our SCARA robot has three joints. The pose of the end frame x_3, y_3, z_3 with respect to the base frame x_0, y_0, z_0 is expressed by the following postmultiplication of three pairs of homogenous transformation matrices

$${}^0\mathbf{H}_3 = ({}^0\mathbf{H}_1\mathbf{D}_1) \cdot ({}^1\mathbf{H}_2\mathbf{D}_2) \cdot ({}^2\mathbf{H}_3\mathbf{D}_3). \quad (2.24)$$

In equation (2.24) the matrices ${}^0\mathbf{H}_1$, ${}^1\mathbf{H}_2$, and ${}^2\mathbf{H}_3$ describe the pose of each joint frame with respect to the preceding frame in the same way as in the case of assembly of the blocs. From Figure 2.11 it is evident that the \mathbf{D}_1 matrix represents a rotation around the positive z_1 axis. The following product of two matrices describes the pose and the displacement in the first joint

$${}^0\mathbf{H}_1\mathbf{D}_1 = \begin{bmatrix} 1 & 0 & 0 & 0 \\ 0 & 1 & 0 & 0 \\ 0 & 0 & 1 & l_1 \\ 0 & 0 & 0 & 1 \end{bmatrix} \begin{bmatrix} c1 & -s1 & 0 & 0 \\ s1 & c1 & 0 & 0 \\ 0 & 0 & 1 & 0 \\ 0 & 0 & 0 & 1 \end{bmatrix} = \begin{bmatrix} c1 & -s1 & 0 & 0 \\ s1 & c1 & 0 & 0 \\ 0 & 0 & 1 & l_1 \\ 0 & 0 & 0 & 1 \end{bmatrix}.$$

In the above matrices the following shorter notation was used: $\sin \vartheta_1 = s1$ and $\cos \vartheta_1 = c1$.

In the second joint there is a rotation around the z_2 axis

$${}^1\mathbf{H}_2\mathbf{D}_2 = \begin{bmatrix} 1 & 0 & 0 & 0 \\ 0 & 1 & 0 & l_2 \\ 0 & 0 & 1 & 0 \\ 0 & 0 & 0 & 1 \end{bmatrix} \begin{bmatrix} c2 & -s2 & 0 & 0 \\ s2 & c2 & 0 & 0 \\ 0 & 0 & 1 & 0 \\ 0 & 0 & 0 & 1 \end{bmatrix} = \begin{bmatrix} c2 & -s2 & 0 & 0 \\ s2 & c2 & 0 & l_2 \\ 0 & 0 & 1 & 0 \\ 0 & 0 & 0 & 1 \end{bmatrix}.$$

In the last joint there is translation along the z_3 axis

$${}^2\mathbf{H}_3\mathbf{D}_3 = \begin{bmatrix} 1 & 0 & 0 & 0 \\ 0 & 1 & 0 & l_3 \\ 0 & 0 & 1 & 0 \\ 0 & 0 & 0 & 1 \end{bmatrix} \begin{bmatrix} 1 & 0 & 0 & 0 \\ 0 & 1 & 0 & 0 \\ 0 & 0 & 1 & -d_3 \\ 0 & 0 & 0 & 1 \end{bmatrix} = \begin{bmatrix} 1 & 0 & 0 & 0 \\ 0 & 1 & 0 & l_3 \\ 0 & 0 & 1 & -d_3 \\ 0 & 0 & 0 & 1 \end{bmatrix}.$$

The geometrical model of the SCARA robot manipulator is obtained by postmultiplication of the three matrices derived above

$${}^0\mathbf{H}_3 = \begin{bmatrix} c12 & -s12 & 0 & -l_3s12 - l_2s1 \\ s12 & c12 & 0 & l_3c12 + l_2c1 \\ 0 & 0 & 1 & l_1 - d_3 \\ 0 & 0 & 0 & 1 \end{bmatrix}.$$

When multiplying the three matrices the following abbreviation was introduced $c12 = \cos(\vartheta_1 + \vartheta_2) = c1c2 - s1s2$ and $s12 = \sin(\vartheta_1 + \vartheta_2) = s1c2 + c1s2$.



<http://www.springer.com/978-90-481-3775-6>

Robotics

Bajd, T.; Mihelj, M.; Lenarcic, J.; Stanovnik, A.; Munih, M.

2010, VIII, 152 p., Hardcover

ISBN: 978-90-481-3775-6