

MPB 2010/11 – Towards the Exam of May 2, 2011



Figura 1: Two systems

[Ex. 1 (6 pt)]

1. Describe the origin and key idea that motivated the paradigm shift to process orientation.
2. Describe the Process Design Methodology.

[Ex. 2 (6 pt)]

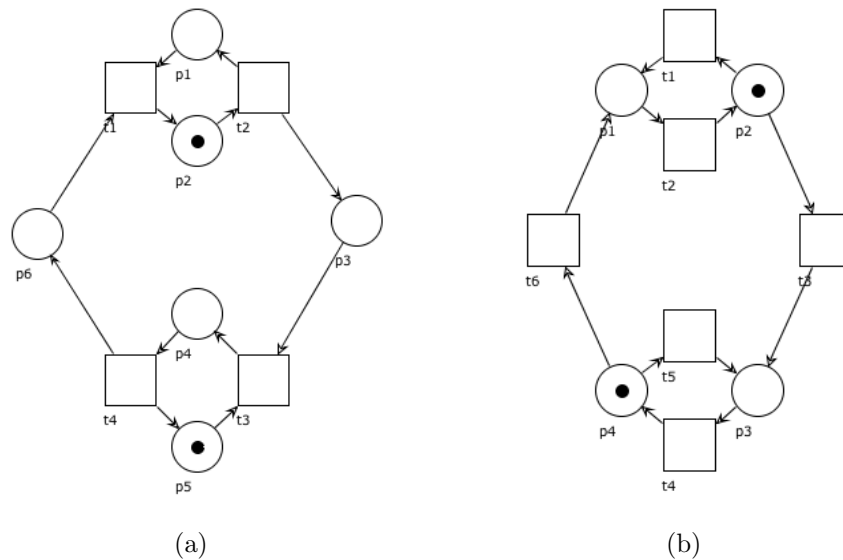
Give the formal definitions for Petri net, pre- and post-set, marking, enabling, firing, firing sequence and reachable marking. Then, illustrate them over an example.

[Ex. 3 (6 pt)]

Consider the net system in Figure 1(a). Say if it is live, deadlock-free, bounded, safe, cyclic.

[Ex. 4 (8 pt)]

Give the formal definition of S-invariant and describe its fundamental property. Then, illustrate the above concepts over an example. Show a counterexample to the conjecture that the existence of a positive S-invariant implies liveness.

[Ex. 5 (6 pt)]

Consider the net in Figure 1(b). Find an S-invariant to prove that $M = p_1 + p_2 + p_3$ is not reachable from $M_0 = p_2 + p_4$.

MPB 2010/11 – Exam May 2, 2011



Figura 1: Two systems

[Ex. 1 (6 pt)]

1. Describe the Business Process Lifecycle.
2. Define the basic terminology of business processes.

[Ex. 2 (6 pt)]

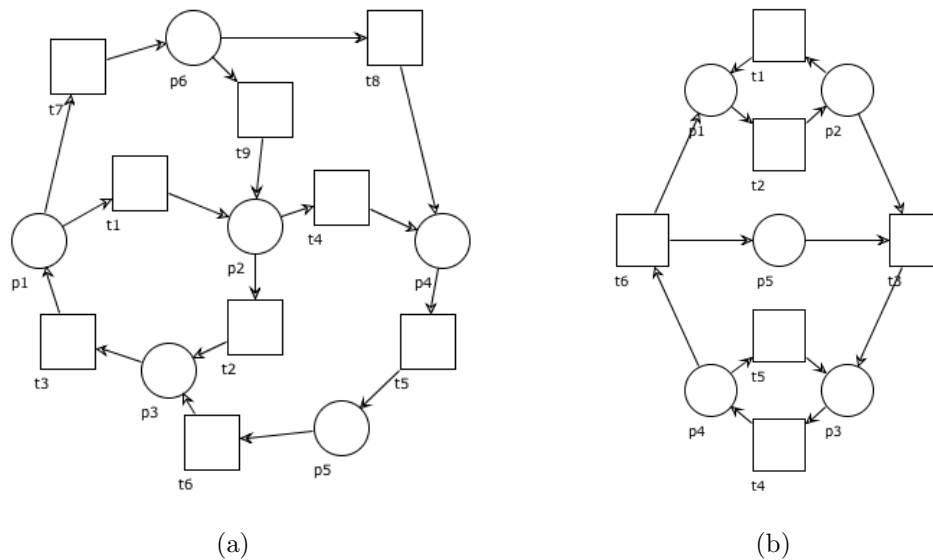
Give the formal definition of liveness and deadlock-freedom. Then, illustrate them over some examples that cover all possible combinations of the two concepts.

[Ex. 3 (6 pt)]

Consider the net in Figure 1(a), say if it is strongly connected, an S-net, a T-net, a free-choice net, or none of them. (Motivate your answers).

[Ex. 4 (8 pt)]

Which of the following sentences is true? Exhibit a simple counterexample for any false sentence.

- existence of a semi-positive S-invariant implies boundedness
- existence of a positive S-invariant implies safeness
- existence of a positive S-invariant implies boundedness

[Ex. 5 (6 pt)]

Consider the net in Figure 1(b). Which of the following are S-invariants? $\mathbf{I}_1 = [1 \ 1 \ 0 \ 0 \ 0]$; $\mathbf{I}_2 = [0 \ 0 \ 1 \ 1 \ 1]$; $\mathbf{I}_3 = [1 \ 1 \ 2 \ 2 \ 1]$; $\mathbf{I}_4 = [2 \ 2 \ 1 \ 1 \ 1]$; $\mathbf{I}_5 = [1 \ 1 \ 1 \ 1 \ 0]$; $\mathbf{I}_6 = [0 \ 1 \ 0 \ 1 \ 1]$. (Explain.)

MPB 2011/12 – Exam November 21, 2011



Figura 1: A T-system and a net

[Ex. 1 (6 pt)]

Describe the key terminology, principles and advantages of Service-Oriented Architectures and of the Enterprise Service Computing.

[Ex. 2 (7 pt)]

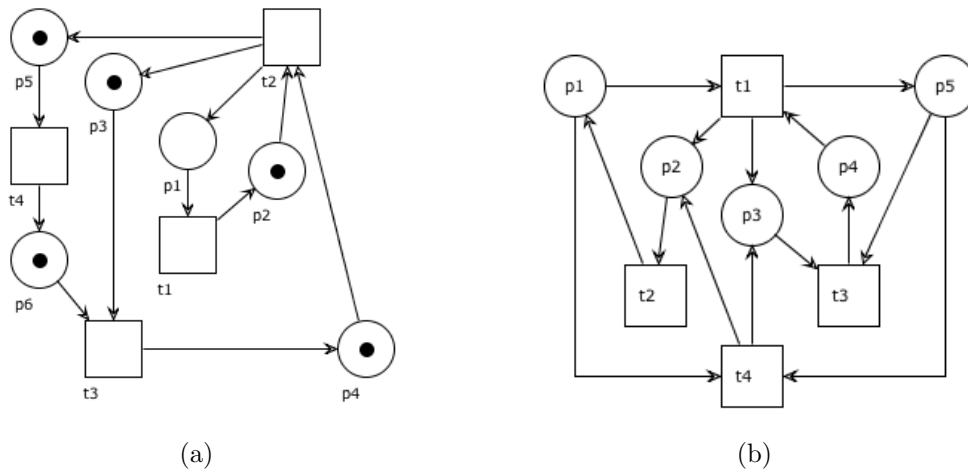
Give the formal definitions for net, S-net, T-net and free-choice net. Then:

1. Draw an S-net that is also a T-net (if it exists).
2. Draw an S-net that is not a T-net (if it exists).
3. Draw a T-net that is not free-choice (if it exists).
4. Draw a net that is not free-choice (if it exists).

[Ex. 3 (8 pt)]

Consider the T-system in Figure 1(a), with $M_0 = p_2 + p_3 + p_4 + p_5 + p_6$.

1. Is it strongly connected? Is it safe? Is it bounded? (explain)
2. Does any place belong to a circuit? Is it live? (explain)
3. Explain why $M = p_2 + 2p_3 + p_4 + p_5$ is not reachable from M_0 .

[Ex. 4 (5 pt)]

Let (P, T, F, M_0) be an S-system and $\mathbf{M} = \{M \mid M(P) = M_0(P)\}$.

Is \mathbf{M} a stable set? Under which condition does $\mathbf{M} = [M_0]$? (explain)

[Ex. 5 (6 pt)]

Consider the net in Figure 1(b).

1. Which of the following are S-invariants? (explain)

$$\mathbf{I}_1 = [1 \ 1 \ 0 \ 0 \ 0] \quad \mathbf{I}_2 = [0 \ 0 \ 1 \ 1 \ 1] \quad \mathbf{I}_3 = [2 \ 2 \ 1 \ 2 \ 1]$$

2. Which of the following are T-invariants? (explain)

$$\mathbf{J}_1 = [1 \ 2 \ 2 \ 1] \quad \mathbf{J}_2 = [1 \ 1 \ 1 \ 0] \quad \mathbf{J}_3 = [0 \ 1 \ 0 \ 1]$$

MPB 2012/13 – Towards the Exam of Nov 7, 2012



Figura 1: Two systems

[Ex. 1 (6 pt)]

1. What is a Business Process?
2. What are the Levels of the Business Process Methodology?

[Ex. 2 (6 pt)]

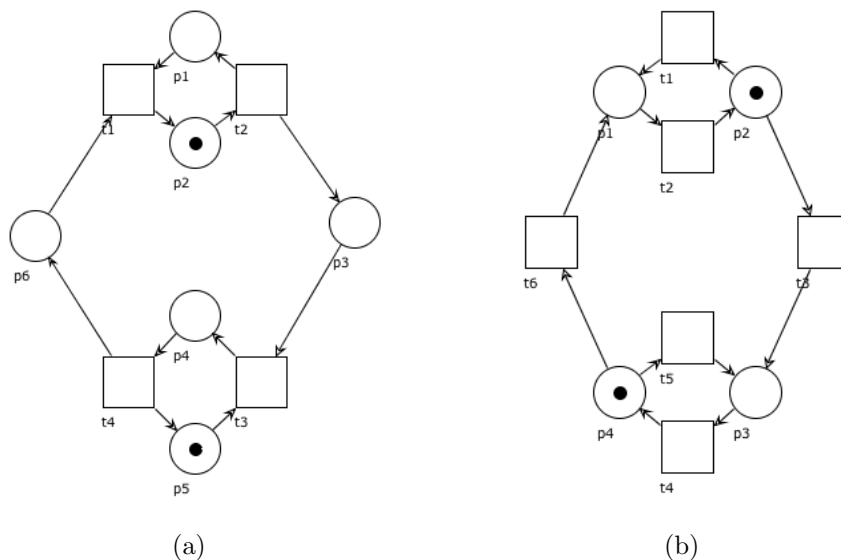
Give the formal definitions for Petri net, pre- and post-set, marking, enabling, firing. Then, illustrate them over an example.

[Ex. 3 (6 pt)]

Consider the net system in Figure 1(a). Say if it is live, deadlock-free, bounded, safe, cyclic.

[Ex. 4 (6 pt)]

Define the matrix and the vector that corresponds to the net in Figure 1(b) and its initial marking.

[Ex. 5 (6 pt)]

Exploit the Marking Equation Lemma to find the marking reached in Figure 1(b) after firing the sequences of transitions $t_6 t_2 t_1 t_3 t_4 t_5$ and $t_5 t_3 t_4 t_6 t_4 t_2 t_5 t_3 t_6$.



Figura 1: Two net systems

[Ex. 1 (6 pt)]

1. What is Business Process Management?
2. What are the phases of the Business Process Lifecycle?

[Ex. 2 (6 pt)]

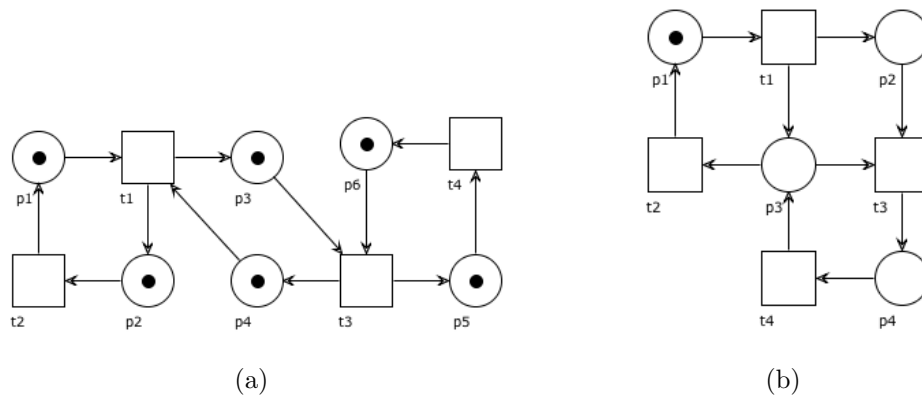
Give the formal definitions of firing and firing sequence. Then, illustrate them over an example.

[Ex. 3 (6 pt)]

Consider the net system in Figure 1(a). Say if it is live, deadlock-free, bounded, safe, cyclic.

[Ex. 4 (6 pt)]

Define the matrix and the vector that corresponds to the net in Figure 1(b) and its initial marking.

[Ex. 5 (6 pt)]

Exploit the Marking Equation Lemma to find the marking reached in Figure 1(b) after firing the sequences of transitions $t_1 t_3 t_4 t_2 t_1 t_2 t_1$ and $t_1 t_2 t_1 t_2 t_1 t_2 t_1 t_3 t_4 t_3 t_4$.

MPB 2013/14 — Towards the Exam of Nov 6, 2013

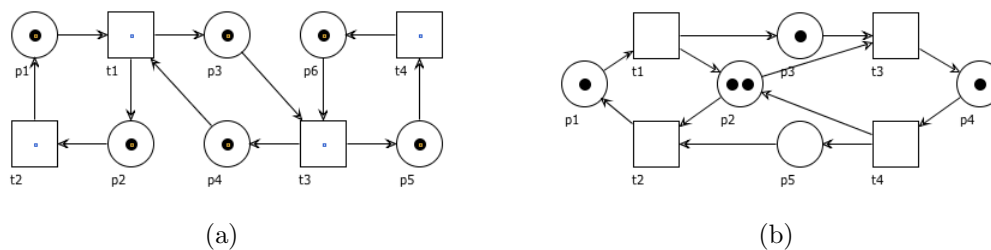

Figure 1: Two systems

[Ex. 1] Describe the difference between orchestration and choreography.

[Ex. 1] Describe the main stakeholders in the process domain.

[Ex. 2] Give the formal definition of bounded place, safe place and unbounded place. Then, show a single net system that contains a safe place, an unbounded place and a bounded place that is not safe.

[Ex. 2] Give the formal definition of deadlock-freedom and cyclicity. Then, illustrate some examples (with non-empty initial markings) that cover all the possible combinations of the two concepts.

[Ex. 3] Consider the net system in Figure 1(a). Say if it is live, deadlock-free, bounded, safe, cyclic.

[Ex. 4] Which of the following sentences is true? Exhibit a counterexample for any false sentence.

- boundedness implies safeness
- safeness implies boundedness
- safeness implies cyclicity

[Ex. 5] Define the net matrix and the initial marking vector that define the net system in Figure 1(b). Then, exploit the Marking Equation Lemma to compute the marking reached after firing the sequence of transitions $t_3 t_1 t_4 t_2 t_3 t_1 t_4 t_3 t_2 t_4 t_1 t_3 t_2 t_4$, and find a suitable invariant to prove that the marking $2p_1 + p_2 + p_3 + p_4$ is not reachable.

[Ex. 5] Prove that the net system in Figure 1(b) is bounded. What is the minimal k for which it is k -bounded.

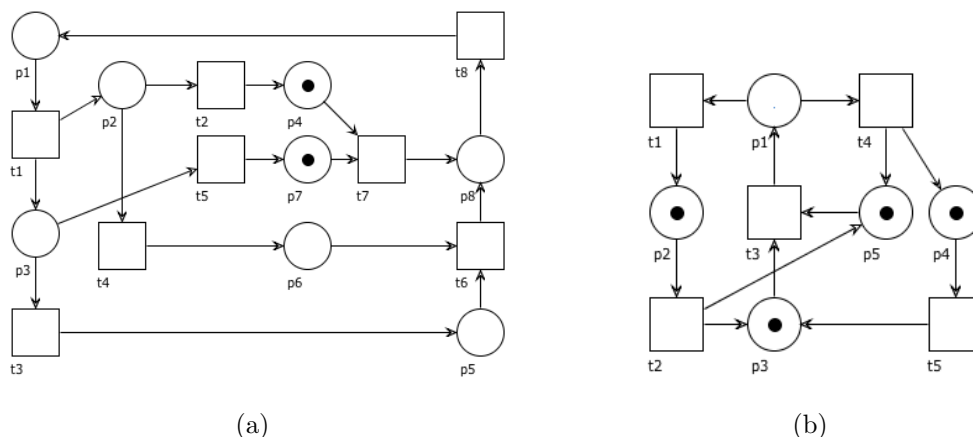

Figure 1: Two net systems

[Ex. 1]

Describe the hierarchical, matrix and network organizational structures and explain their differences.

[Ex. 2]

Give the formal definitions of live transition, dead transition and live system. Then, illustrate them over positive (e.g. live transition, etc.) and negative (e.g. non-live transition, etc.) examples.

Can you define a net system with a non-live transition that is not dead?

[Ex. 3]

Consider the net system in Figure 1(a). Draw the complete reachability graph and then say if it is live, place-live, deadlock-free, bounded, safe, cyclic, motivating each answer.

[Ex. 4]

Exploit the Marking Equation Lemma to find the marking reached in Figure 1(a) after firing the sequence of transitions $t_7 t_8 t_1 t_4 t_3 t_6 t_8 t_1 t_3$.

[Ex. 5]

Consider the net system in Figure 1(b). Prove that the marking $p_1 + p_2 + p_3 + p_4$ is not reachable without computing the reachability graph.

MPB 2014/15 – Nov 7, 2014

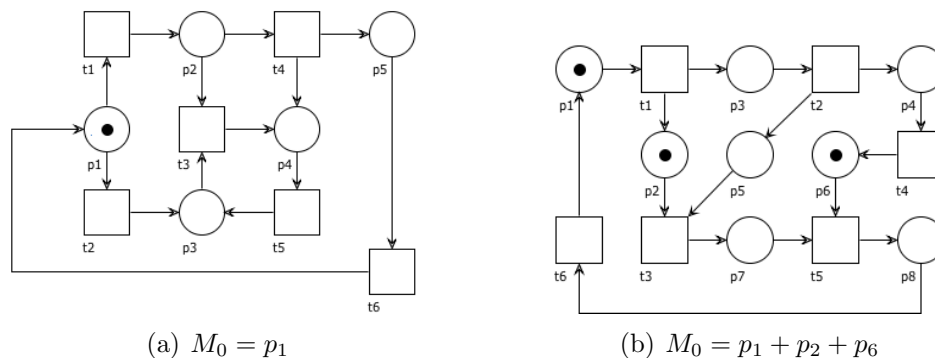

Figure 1: Two net systems

[Ex. 1]

Explain the meaning of the following terms in the context of business process management: “task”, “resource”, “activity”, “principal”, “contractor”.

[Ex. 2] Consider a net system (P, T, F, M_0) .

Give a formal definition of each of the following three statements: “a deadlock state is reachable”; “the place p is dead”; “the transition t is not live”.

[Ex. 3] Consider the net system in Figure 1(a).

Prove that the system is not deadlock-free.

Is the system live (explain)?

Is the system free-choice (explain)?

Prove that the place p_3 is unbounded by exploiting the Monotonicity Lemma (hint: find two suitable reachable markings $M \subset M'$ such that $M' \in [M]$).

[Ex. 4] Consider the net system in Figure 1(a).

Exploit the Marking Equation Lemma to find the marking reached after firing the sequence $\sigma = t_1 t_4 t_6 t_1 t_5 t_4 t_5 t_6 t_1 t_4 t_6 t_2$.

Exploit the Marking Equation Lemma to justify the fact that the firing sequence $\sigma' = t_1 t_4 t_6 t_1 t_5 t_3 t_5 t_4 t_6 t_1 t_3 t_4$ is not enabled.

[Ex. 5] Consider the net system in Figure 1(b).

Prove that the system is bounded by exhibiting a suitable S-invariant.

Exploit the fundamental property of S-invariants to prove that the marking $M = p_2 + p_4 + p_6 + p_8$ is not reachable.

[Ex. 6, Optional]

Describe the “Design & Analysis” phase of the business process lifecycle.